



# MAX5074 Evaluation Kit

**Evaluates: MAX5074**

## General Description

The MAX5074 evaluation kit (EV kit) is a fully assembled and tested circuit board that contains a high-efficiency, 14W, forward DC-DC converter in the industry-standard 1/8th-brick footprint. The circuit is configured for a 12V output voltage and provides up to 1.2A of current. Power for the circuit can be provided from a 36V to 72V DC source as well as sources used in the telecom/data-com markets, industrial environments, and in automotive 42V power systems.

The EV kit uses the MAX5074 IC that includes internal power MOSFETs. High efficiency up to 85% at 1.2A is achieved using an internally clamped two-transistor topology. Part of the efficiency improvement is due to the recovery of stored leakage and magnetizing inductance energy at the primary side.

The MAX5074 is programmed to switch at 250kHz. The undervoltage lockout (UVLO) threshold is programmed to 30V and the integrated fault protection provides effective fault management. Output galvanic isolation is achieved by an optocoupler and the surface-mount power transformer.

**Warning:** The MAX5074 EV kit is designed to operate with high voltages. Dangerous voltages are present on this EV kit and on equipment connected to it. Users who power up this EV kit or power the sources connected to it must be careful to follow safety procedures appropriate to working with high-voltage electrical equipment.

Under severe fault or failure conditions, this EV kit may dissipate large amounts of power, which could result in the mechanical ejection of a component or of component debris at high velocity. Operate this kit with care to avoid possible personal injury.

The EV kit user should not probe the circuit with an oscilloscope probe and ground clip unless they have experience with high voltages.

## Features

- ◆ Isolated 14W Forward DC-DC Converter
- ◆ 36V to 72V Input Range
- ◆ 12V Output Provides Up to 1.2A
- ◆ 85% Efficiency at 48V and 1.2A
- ◆ 1/8th-Brick Module Footprint
- ◆ Cycle-by-Cycle Current-Limit Protection
- ◆ Programmable Integrating Fault Protection
- ◆ Programmed for 250kHz Switching Frequency
- ◆ Internal Thermal Shutdown
- ◆ Basic Primary to Secondary Isolation
- ◆ Soft-Start
- ◆ Fully Assembled and Tested

## Ordering Information

PART	TEMP RANGE	IC PACKAGE
MAX5074EVKIT	0°C to +50°C	20 TSSOP-EP*

\*EP = Exposed pad.

## Component List

DESIGNATION	QTY	DESCRIPTION
C1	1	4.7µF ±10%, 16V X7R ceramic capacitor (1206) TDK C3216X7R1C475K
C2	1	100pF ±5%, 50V C0G ceramic capacitor (0603) TDK C1608C0G1H101K
C3, C5, C7, C17	4	0.1µF ±10%, 50V X7R ceramic capacitors (0603) TDK C1608X7R1H104K

DESIGNATION	QTY	DESCRIPTION
C4, C6	2	220pF ±10%, 50V X7R ceramic capacitors (0603) TDK C1608X7R1H221K
C8	1	1.0µF ±10%, 50V X7R ceramic capacitor (1206) TDK C3216X7R1H105K
C9	1	1.0µF ±20%, 100V X7R ceramic capacitor (1210) TDK C3225X7R2A105M



# MAX5074 Evaluation Kit

Evaluates: MAX5074

## Component List (continued)

DESIGNATION	QTY	DESCRIPTION
C10, C11	2	0.01 $\mu$ F $\pm$ 10%, 100V X7R ceramic capacitors (0805) TDK C2012X7RZA103K or Murata GRM21BR72A103K
C12	1	0.15 $\mu$ F $\pm$ 10%, 25V X7R ceramic capacitor (0603) TDK C1608X7R1E154K
C13	1	0.047 $\mu$ F $\pm$ 10%, 16V X7R ceramic capacitor (0603) Murata GRM188R71E473K
C14	1	0.33 $\mu$ F $\pm$ 10%, 16V X7R ceramic capacitor (0603) TDK C1608X7R1C334K
C15, C16	2	47 $\mu$ F $\pm$ 20%, 16V POSCAP capacitors (D2) Sanyo 16TQC47M
C18	1	0.0047 $\mu$ F $\pm$ 10%, 250VAC X7R ceramic capacitor (2220) Murata GA355DR7GC472KY
D1, D2, D5	3	120V, 200mA fast-switching diodes (SOD-323) Diodes Incorporated BAV19WS
D3, D4	2	80V, 2A Schottky diodes (SMB) Diodes Incorporated B280

DESIGNATION	QTY	DESCRIPTION
L1	1	68 $\mu$ H, 2.1A inductor Coilcraft MSS1278-683MX
R1	1	143k $\Omega$ $\pm$ 1% resistor (0603)
R2	1	16.2k $\Omega$ $\pm$ 1% resistor (0603)
R3	1	562 $\Omega$ $\pm$ 1% resistor (0805)
R4	1	0.1 $\Omega$ , 0.5W $\pm$ 1% resistor (1206) IRC LRC-LR1206-01-R100-F
R5	1	316k $\Omega$ $\pm$ 1% resistor (0603)
R6	1	14.7k $\Omega$ $\pm$ 1% resistor (0603)
R7	1	1.78k $\Omega$ $\pm$ 1% resistor (0603)
R8	0	Not installed, resistor (0603)
R9	1	24.9k $\Omega$ $\pm$ 1% resistor (0603)
R10	1	1M $\Omega$ $\pm$ 5% resistor (0603)
R11	1	200k $\Omega$ $\pm$ 1% resistor (0603)
R12	1	100 $\Omega$ $\pm$ 1% resistor (0603)
R13	1	604 $\Omega$ $\pm$ 1% resistor (0603)
R14	1	15 $\Omega$ $\pm$ 5% resistor (0603)
T1	1	18W Transformer Coilcraft C0984-C
U1	1	<b>MAX5074AUP (20-pin TSSOP-EP)</b>
U2	1	30V, 100% to 200% CTR optically isolated error amplifier (8-pin SO) Fairchild Semiconductor FOD2712
None	1	MAX5074 PC board

## Component Suppliers

SUPPLIER	PHONE	FAX	WEBSITE
Coilcraft	847-639-6400	847-639-1469	www.coilcraft.com
Diodes Inc	805-446-4800	805-446-4850	www.diodes.com
Fairchild Semiconductor	888-522-5372	—	www.fairchildsemi.com
IRC	361-992-7900	361-992-3377	www.irctt.com
Murata	770-436-1300	770-436-3030	www.murata.com
Sanyo Electronic Device	619-661-6322	619-661-1055	www.sanyodevice.com
TDK	847-803-6100	847-390-4405	www.component.tdk.com

**Note:** Indicate that you are using the MAX5074 when contacting these component suppliers.

# MAX5074 Evaluation Kit

Evaluates: MAX5074

## Quick Start

### Required Equipment

- 30V to 80V, 2A power supply
- Voltmeter

The MAX5074 EV kit is fully assembled and tested. Follow these steps to verify board operation. **Do not turn on the power supply until all connections are completed:**

- 1) Connect a 33 $\mu$ F, 100V bulk capacitor at the VIN and PGND terminals.
- 2) Connect the 30V to 80V power supply to the VIN pinhole. Connect the power supply's ground to the PGND pinhole. **Do not exceed 80V input voltage.**
- 3) Connect a voltmeter to the VOUT and SGND pinholes.
- 4) Turn on the power supply and set the voltage above 48V.
- 5) Verify that VOUT measures 12V at the voltmeter.

## Detailed Description

The MAX5074 EV kit is an isolated 14W forward DC-DC converter that provides 12V at up to 1.2A at the output. The circuit can be powered from a 36V to 72V DC source that provides at least 2A.

The 14W forward converter achieves high efficiency by using a clamped two-transistor power topology with both power transistors integrated on the MAX5074 IC. Current-sense resistor R4 senses the current through the primary of transformer T1 and then turns off both internal transistors when the trip level of 156mV is reached. For a continuous short circuit at the output, the fault-integration feature provides hiccup fault protection, thus greatly minimizing destructive temperature rise. Fault integration times can be adjusted with resistor R10 and capacitor C3.

The surface-mount transformer features a bias winding, which, along with diode D5, resistor R14, and capacitor C8, powers the MAX5074 IC after the undervoltage lockout threshold is exceeded. No reset windings are required with a clamped two-transistor power topology. Diodes D1 and D2 recover the magnetic energy stored in the transformer and feed it back to the input. The transformer provides primary-to-secondary galvanic isolation.

On the transformer's secondary side, optically isolated error amplifier (U2) along with feedback resistors R1 and R2 provide voltage feedback to the primary side. The MAX5074 receives the voltage feedback signal on

the primary side from biasing resistor R7 and compensation resistor/capacitor network R13/C14.

The MAX5074 IC switches at a preconfigured 250kHz frequency set by resistor R9 and capacitor C2.

The 4-layer PC board layout and component placement has been designed for the industry-standard 1/8th-brick footprint and pinout. The PC board top and bottom layers are designed with 2oz copper for improved performance.

### Undervoltage Lockout (UVLO)

The MAX5074 EV kit requires a 36V to 72V, 2A DC source connected across the VIN and PGND pin-holes for normal operation. The MAX5074 EV kit UVLO is programmed to 30V by resistors R5 and R6. Use the following equation to calculate new resistor values for R5 and R6 to reconfigure the UVLO threshold.

$$R5 = \left( \frac{V_{INSTARTUP}}{1.25V} - 1 \right) \times R6$$

where  $V_{INSTARTUP}$  is the new undervoltage threshold and resistor R6 is typically 14.7k $\Omega$ . The turns ratio of transformer T1 may have to change to accommodate the desired operating range.

### Output Voltage (VOUT)

The MAX5074 EV kit's output (VOUT) is set to 12V by feedback resistors R1 and R2. To generate output voltages other than 12V, in the range of 8V to 13V, select different values for voltage-divider resistors R1 and R2. Use the following equation to select new resistor values.

$$R1 = \left( \frac{V_{OUT}}{1.24V} - 1 \right) \times R2$$

where R2 is typically 16.2k $\Omega$  and  $V_{OUT}$  is the desired output voltage. Inductor L1 and transformer T1 may require replacement after reconfiguring the output voltage setting. The minimum output voltage is limited by resistor R3 and optocoupler U2.

# MAX5074 Evaluation Kit

## Switching Frequency

The MAX5074 EV kit switching frequency is programmed to 250kHz with resistor R9 and capacitor C2. The switching frequency can be reprogrammed by replacing these components. Refer to the *Oscillator* section in the MAX5074 data sheet for details on selecting new values.

## Current Limiting

The EV kit features primary-side cycle-by-cycle current limit. The MAX5074 IC turns off both internal switching transistors when the voltage at the CS pin of the MAX5074 reaches 156mV. Current-sense resistor R4 limits the peak primary current to approximately 1.56A (156mV / 0.1Ω = 1.56A). This limits short-circuit current on the secondary output (VOOUT) to approximately 2A. To evaluate different current limits, current-sense resistor R4 must be replaced with a different value surface-mount resistor (1206 size) as determined by the following equation:

$$R4 = \frac{156\text{mV}}{I_{\text{LIM}}}$$

where  $I_{\text{LIM}}$  is the desired maximum peak primary-side current limit.

## Integrating Fault Protection

The MAX5074 IC integrates a fault protection feature that ignores transient overcurrent conditions for a programmable amount of time. The initial ignore time is programmed to 3.2ms with capacitor C3. Use the following equation to reconfigure the initial overcurrent ignore time:

$$C3 \cong \frac{80\mu\text{A} \times t_{\text{SH}}}{2.7}$$

where  $t_{\text{SH}}$  is the desired ignore time.

Once the ignore time is exceeded, the MAX5074 IC stops switching and resistor R10 discharges capacitor C3 towards the internal restart threshold of 1.9V during the recovery time interval of 35ms. Use the following equation to select a new value for resistor R10 to adjust the recovery time:

$$R10 \cong \frac{t_{\text{RT}}}{C3 \times \ln\left[\frac{2.7}{1.9}\right]}$$

where  $t_{\text{RT}}$  is the new recovery time. Select a recovery time that is at least 10 times longer than the ignore time  $t_{\text{SH}}$ . Refer to the *Integrating Fault Protection* section in the MAX5074 data sheet for additional information.

# MAX5074 Evaluation Kit

Evaluates: MAX5074

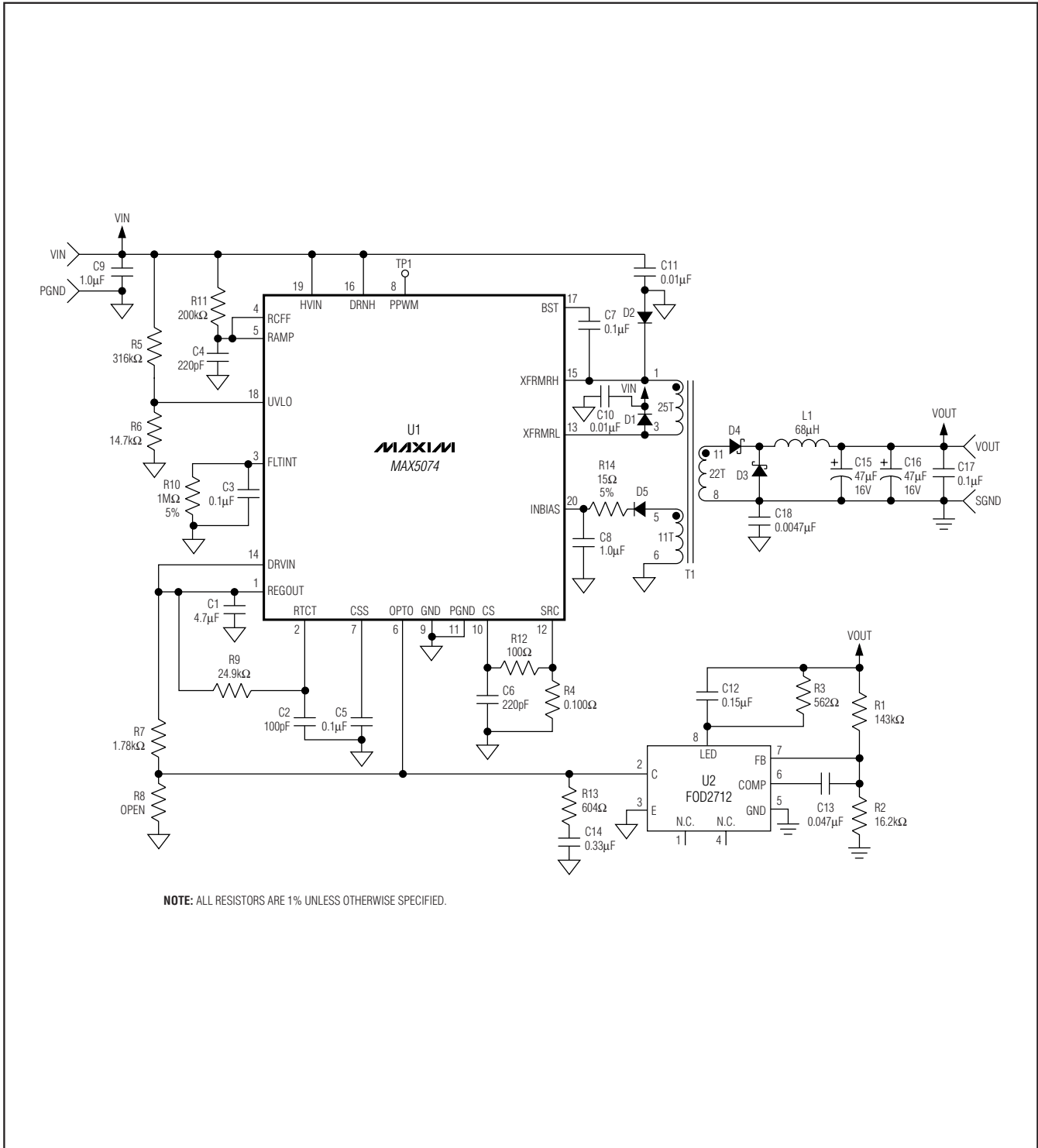

Figure 1. MAX5074 EV Kit Schematic

# MAX5074 Evaluation Kit

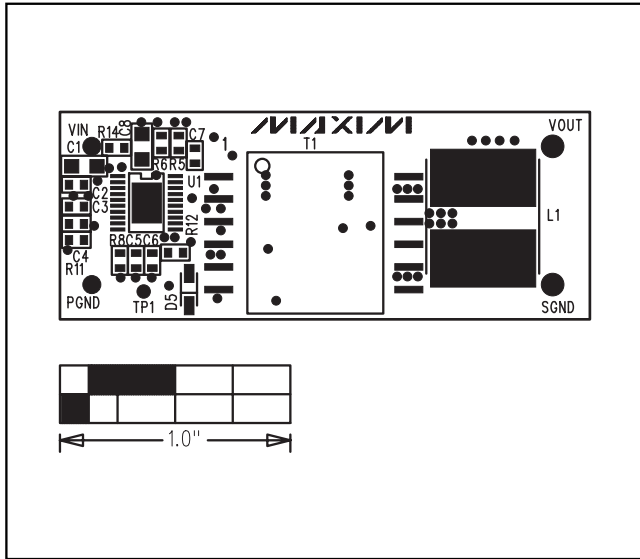

Figure 2. MAX5074 EV Kit Component Placement Guide—Component Side

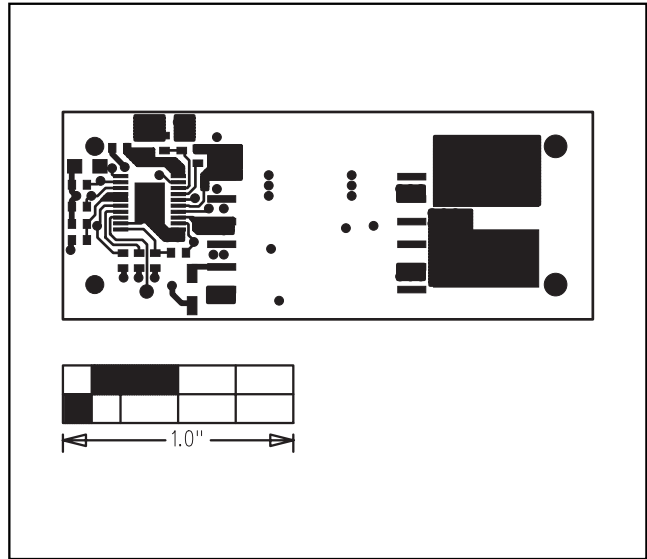

Figure 3. MAX5074 EV Kit PC Board Layout—Layer 1, Component Side

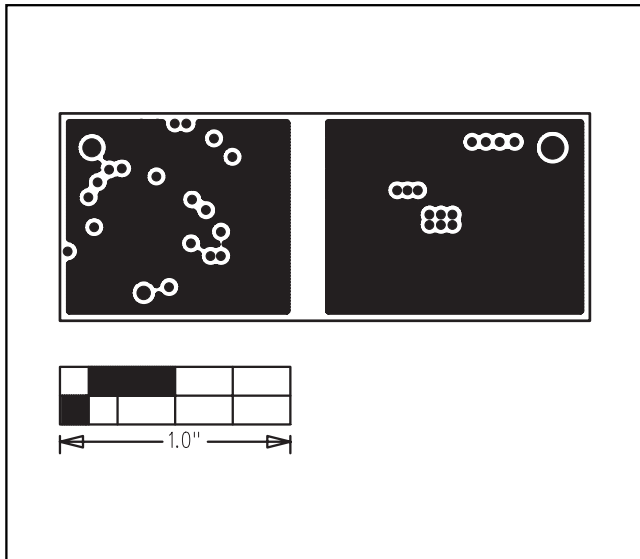

Figure 4. MAX5074 EV Kit PC Board Layout—Layer 2, Ground Planes

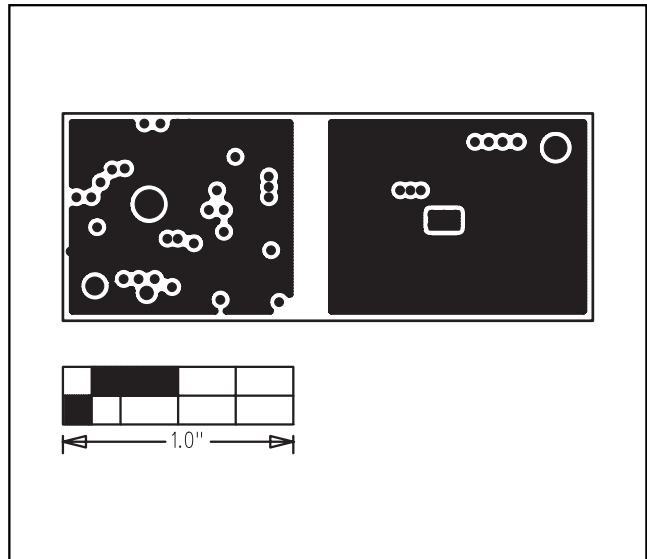

Figure 5. MAX5074 EV Kit PC Board Layout—Layer 3, Power and Ground Planes

# MAX5074 Evaluation Kit

Evaluates: MAX5074

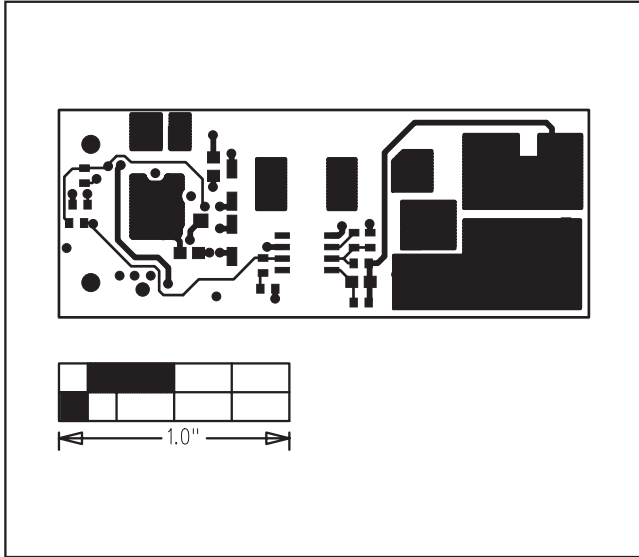

Figure 6. MAX5074 EV Kit PC Board Layout—Layer 4, Solder Side

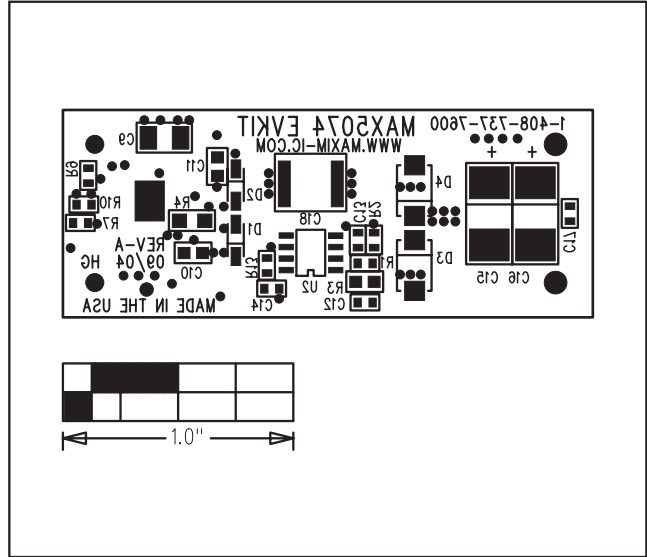

Figure 7. MAX5074 EV Kit Component Placement Guide—Solder Side

Maxim cannot assume responsibility for use of any circuitry other than circuitry entirely embodied in a Maxim product. No circuit patent licenses are implied. Maxim reserves the right to change the circuitry and specifications without notice at any time.

**Maxim Integrated Products, 120 San Gabriel Drive, Sunnyvale, CA 94086 408-737-7600** \_\_\_\_\_ 7